

D70 is a large surface contact with 2x spare terminals, suitable for wiring in single or shared zones.

Operating Gap: ~40mm

Note:
Mounting on metal surfaces reduces the operating gap, according to the metal type and thickness.

Single Zone Wiring (4-Wire):

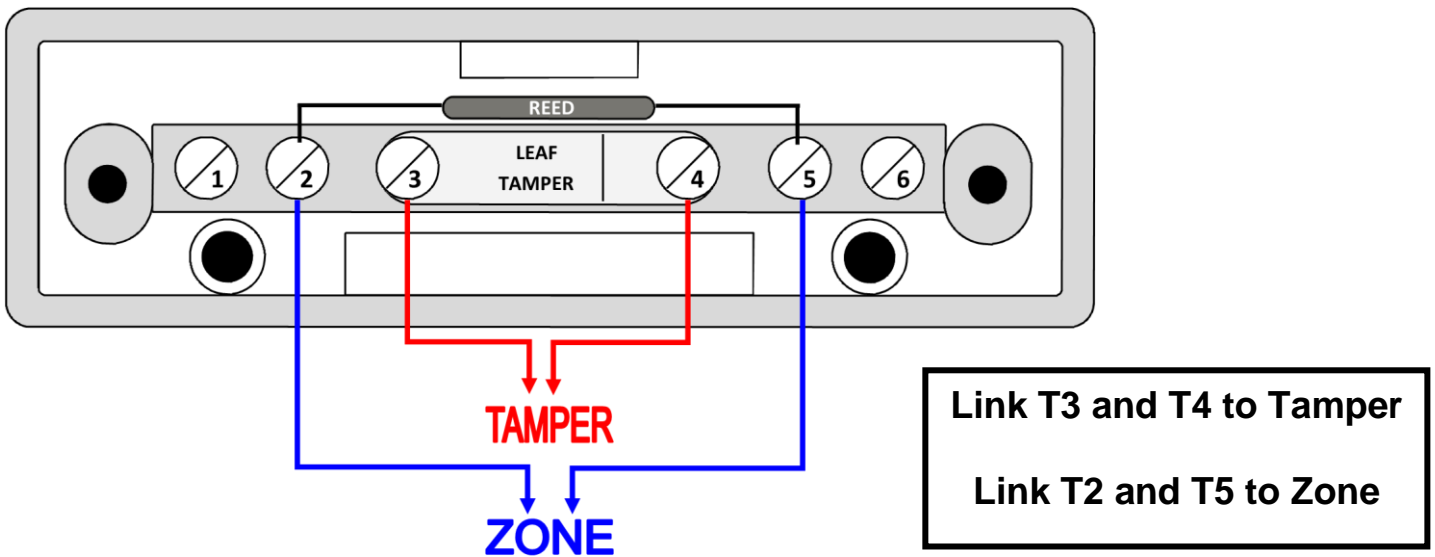

Shared Zone Wiring (4-Wire):

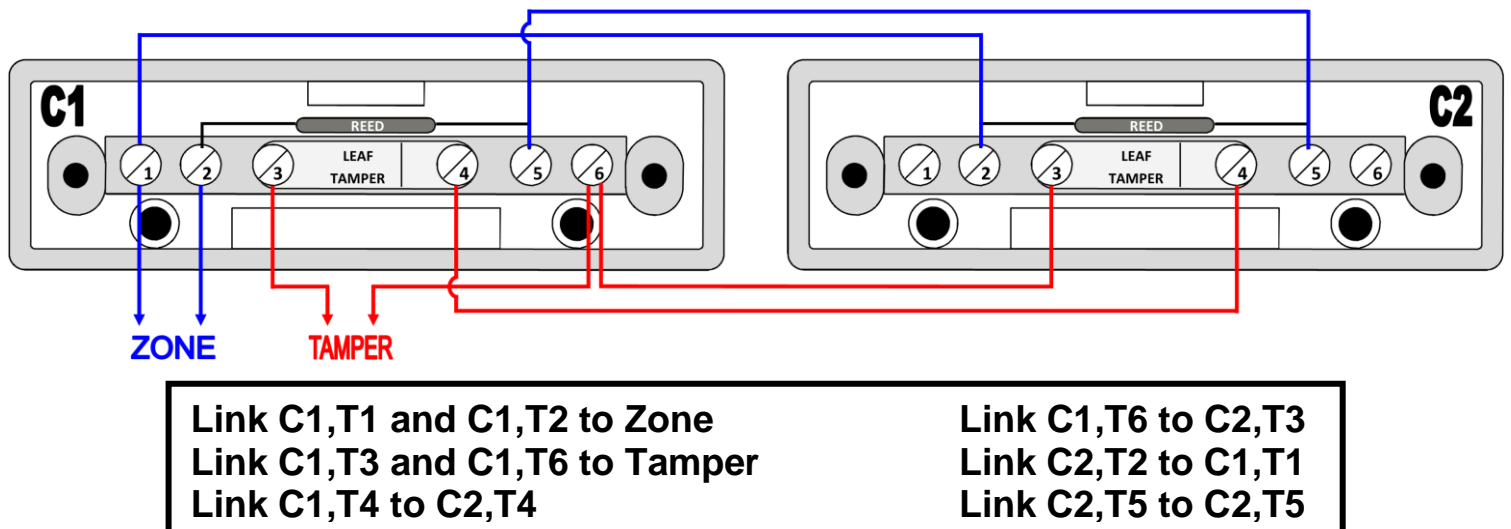

Single Zone Wiring (Supervised):

Add EOL and Alarm resistors as per receiving equipment requirements.

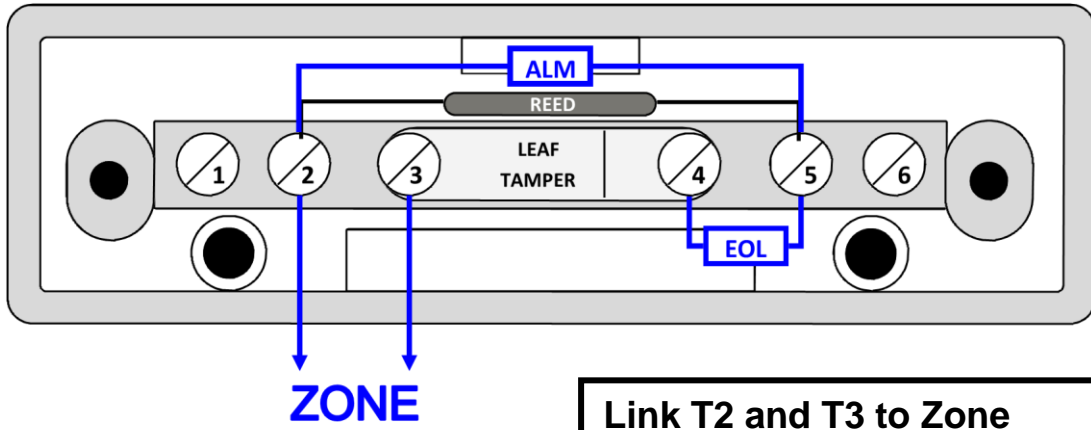

Link T2 and T3 to Zone
Link T2 and T5 to ALM Resistor
Link T4 and T5 to EOL Resistor

Shared Zone Wiring (Supervised):

Add EOL and Alarm resistors as per receiving equipment requirements.

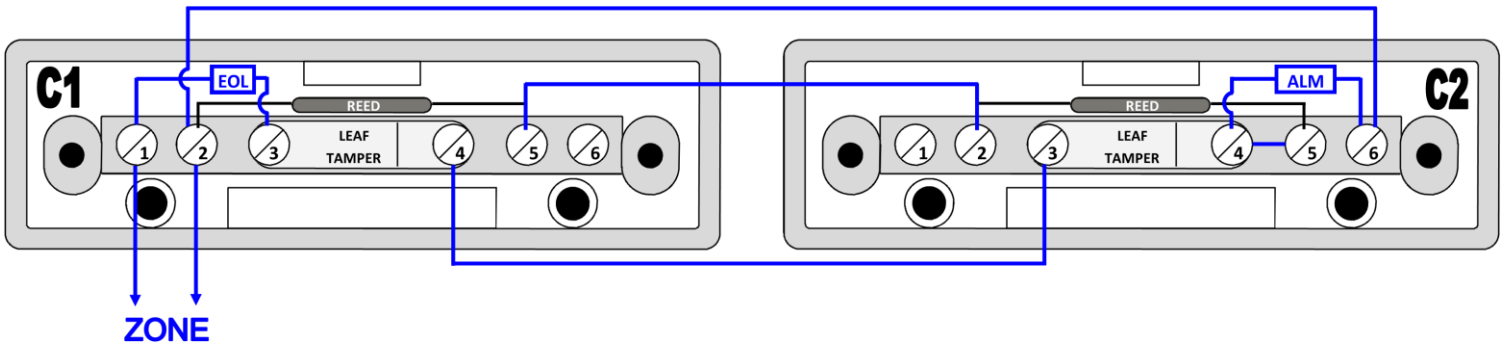

Link C1,T1 and C1,T2 to Zone
Link C1,T1 and C1,T3 to EOL Resistor
Link C1,T2 to C2,T6
Link C1,T4 to C2,T3
Link C1,T5 to C2,T2
Link C2,T4 to C2,T5
Link C2,T4 and C2,T6 to ALM Resistor